

DANFOSS BOCK® Plusbox VSD UNITS

BOCK® Plusbox VSD Condensing Units

BOCK® Plusbox outdoor condensing units are built utilizing BOCK® semi-hermetic compressors & coupled with generously sized condensers ensure a unit that is flexible, efficient & reliable suitable for most climate conditions.

Plusbox units supplied by Airefrig Australia Pty Ltd are fitted as standard with a Danfoss FC103 frequency drive that allows the compressor to be driven up to frequencies of 70Hz and down to 25Hz for efficient capacity control.

The Plusbox includes other quality components such as XGE fan speed controller, low-noise AC condenser fan, liquid receiver, liquid & suction pipework including liquid drier & sight glass, MP55 differential oil pressure switch, dual pressure control, robust weatherproof powder-coated acoustically lined steel housing & is fully wired.

Main Product Features

- BOCK® semi-hermetic compressor in acoustically lined enclosure
- Stepless capacity control 25Hz - 70Hz (Danfoss FC103 Inverter)
- Generously sized condenser for all climate zones
- Weatherproofed powder coated steel sheet housing
- Low noise condenser fan
- High efficiency condensing unit
- Service friendly – easy accessible
- Supports AC & MT & LT applications
- Suitable Refrigerants:
 - R404A, R507, R448A, R449A, R134A & R513A
 - Suitable for most A1 Refrigerants
- Complete liquid and suction pipework
- Liquid line DML drier & SGN sight glass
- Flexible control lines
- XGE fan speed controller
- Electrical switch board
- Main isolator
- Electrical wiring of all components
- Compressor oil sump heater
- KP17WB Dual pressure switch (HP/LP)
- MP55 Differential oil pressure switch
- Oil Separator
- Production Locations
 - Condensing units:
 - Germany
 - Compressors:
 - Germany
 - Czech Republic



Danfoss FC103
Frequency Drive



BOCK® HGX34e
Compressor



DANFOSS BOCK® Plusbox VSD UNITS

Unit Model: SHGX34e/215-4S R404A (R507)

Unit Model	Comp Speed	Amb Temp °C	Refrigeration Capacity Watts											
			Based on 10K suction gas superheat & 3.0K sub-cooling (outside cond.)											
			Evaporating Temperature °C											
			-40	-35	-30	-25	-20	-15	-10	-5	0	+5	+10	
SHGX34e/215-4S (Three Phase) Danfoss Unit Code: 114V16134 Nominal HP: 5.0 hp Bock Compressor: HGX34e/215-4 S Comp Displacement: (50Hz / 1450rpm) 18.8 m ³ /h Comp Max Working Current 50Hz: *Y = 10.5 amps **Δ = 18.3 amps Condenser Fan (Max) Current = 2.6 amps Consumption = 600w Condenser Airflow: 7895 m ³ /h at 50Hz Shut Off Valves: Liquid Line: 1/2" Suction Line: 1-1/8" Receiver Capacity: 8.0 litres Unit Weight: 201 kg	25 Hz	32	834	1270	1790	2430	3190	4090	5140	6340	7710	9250	-	
		38	699	1070	1540	2100	2780	3590	4540	5640	6900	8340	-	
		43	591	917	1330	1830	2440	3180	4050	5070	6240	7590	-	
	35 Hz	32	1190	1790	2520	3410	4460	5690	7100	8720	10600	12600	-	
		38	992	1520	2160	2940	3880	4980	6270	7750	9430	11400	-	
		43	838	1300	1870	2560	3400	4410	5580	6950	8510	10400	-	
	45 Hz	32	1510	2270	3180	4280	5580	7080	8810	10800	13000	15400	-	
		38	1260	1920	2720	3690	4850	6200	7760	9540	11600	13900	-	
		43	1070	1640	2350	3210	4250	5470	6900	8540	10500	12600	-	
	50 Hz (1450 rpm)	32	1660	2490	3490	4680	6090	7710	9570	11700	14100	16700	-	
		38	1390	2110	2980	4040	5290	6740	8420	10400	12500	15000	-	
		43	1170	1800	2580	3510	4630	5950	7490	9250	11300	13600	-	
	55 Hz	32	1800	2700	3780	5060	6570	8300	10300	12600	15000	17800	-	
		38	1510	2280	3230	4360	5700	7250	9040	11100	13400	16000	-	
		43	1270	1950	2790	3790	4990	6400	8030	9900	12100	14500	-	
	65 Hz	32	2070	3090	4310	5760	7440	9370	11600	14100	16800	19800	-	
		38	1730	2610	3680	4950	6450	8180	10200	12400	14900	17700	-	
		43	1460	2230	3170	4300	5640	7210	9010	11100	13400	16100	-	
	70 Hz	32	Information Available on Request											
		38												
		43												
	Compressor Voltage: **220-240V Δ / *380-420V Y - 3 - 50Hz													
	Fan Motor Voltage: 230V - 1 - 50Hz													

DANFOSS BOCK® Plusbox VSD UNITS

Unit Model: SHGX34e/215-4S R448A

Unit Model	Comp Speed	Amb Temp °C	Refrigeration Capacity Watts											
			Based on 10K suction gas superheat & 3.0K sub-cooling (outside cond.)											
			Evaporating Temperature °C											
			-40	-35	-30	-25	-20	-15	-10	-5	0	+5	+10	
SHGX34e/215-4S (Three Phase) Danfoss Unit Code: 114V16134 Nominal HP: 5.0 hp Bock Compressor: HGX34e/215-4 S Comp Displacement: (50Hz / 1450rpm) 18.8 m ³ /h Comp Max Working Current 50Hz: *Y = 10.5 amps **Δ = 18.3 amps Condenser Fan (Max) Current = 2.6 amps Consumption = 600w Condenser Airflow: 7895 m ³ /h at 50Hz Shut Off Valves: Liquid Line: 1/2" Suction Line: 1-1/8" Receiver Capacity: 8.0 litres Unit Weight: 201 kg	25 Hz	32	602	992	1480	2080	2800	3660	4680	5860	7220	8760	10500	
		38	476	821	1260	1790	2450	3240	4180	5280	6550	8000	9640	
		43	401	706	1100	1580	2180	2900	3770	4800	6000	7370	8930	
	35 Hz	32	851	1410	2090	2910	3910	5090	6480	8070	9890	12000	14300	
		38	675	1170	1770	2520	3420	4510	5780	7260	8960	10900	13100	
		43	-	1010	1550	2220	3040	4040	5220	6600	8200	10100	-	
	45 Hz	32	1080	1780	2630	3660	4900	6350	8040	9980	12200	14700	17400	
		38	856	1480	2240	3170	4290	5620	7170	8970	11000	13300	15900	
		43	-	1280	1950	2790	3810	5040	6480	8150	10100	12300	-	
	50 Hz (1450 rpm)	32	1190	1950	2880	4010	5350	6920	8750	10900	13200	15800	18700	
		38	941	1620	2450	3460	4680	6120	7800	9730	12000	14400	-	
		43	-	1400	2140	3060	4170	5490	7040	8840	10900	13200	-	
	55 Hz	32	1290	2110	3120	4330	5770	7460	9400	11700	14100	16900	19900	
		38	1030	1760	2660	3750	5050	6600	8380	10500	12800	15400	-	
		43	-	1520	2320	3310	4500	5910	7570	9480	11700	14100	-	
	65 Hz	32	1470	2410	3560	4930	6550	8430	10600	13100	15800	18800	-	
		38	1180	2010	3030	4270	5730	7450	9440	11700	14300	17100	-	
		43	-	1750	2660	3770	5110	6690	8520	10700	13000	-	-	
	70 Hz	32	Information Available on Request											
		38												
		43												
	Compressor Voltage: **220-240V Δ / *380-420V Y - 3 - 50Hz													
	Fan Motor Voltage: 230V - 1 - 50Hz													

DANFOSS BOCK® Plusbox VSD UNITS

Unit Model: SHGX34e/215-4S R449A

Unit Model	Comp Speed	Amb Temp °C	Refrigeration Capacity Watts											
			Based on 10K suction gas superheat & 3.0K sub-cooling (outside cond.)											
			Evaporating Temperature °C											
			-40	-35	-30	-25	-20	-15	-10	-5	0	+5	+10	
SHGX34e/215-4S (Three Phase) Danfoss Unit Code: 114V16134 Nominal HP: 5.0 hp Bock Compressor: HGX34e/215-4 S Comp Displacement: (50Hz / 1450rpm) 18.8 m³/h Comp Max Working Current 50Hz: *Y = 10.5 amps **Δ = 18.3 amps Condenser Fan (Max) Current = 2.6 amps Consumption = 600w Condenser Airflow: 7895 m³/h at 50Hz Shut Off Valves: Liquid Line: 1/2" Suction Line: 1-1/8" Receiver Capacity: 8.0 litres Unit Weight: 201 kg	25 Hz	32	599	986	1470	2060	2780	3640	4650	5830	7180	8710	10500	
		38	472	815	1250	1780	2430	3220	4150	5240	6510	7950	9580	
		43	398	700	1090	1570	2160	2880	3750	4770	5950	7320	8880	
	35 Hz	32	847	1400	2070	2900	3890	5060	6440	8030	9840	11900	14200	
		38	670	1160	1760	2500	3400	4480	5740	7220	8900	10900	13000	
		43	-	993	1530	2200	3020	4010	5180	6560	8140	9950	-	
	45 Hz	32	1080	1770	2610	3640	4870	6320	8000	9920	12100	14600	17300	
		38	850	1460	2220	3140	4260	5580	7130	8910	11000	13300	15800	
		43	-	1270	1940	2770	3780	5000	6430	8090	9990	12200	-	
	50 Hz (1450 rpm)	32	1180	1940	2860	3980	5320	6880	8700	10800	13100	15700	18600	
		38	934	1610	2430	3440	4650	6080	7750	9660	11900	14300	-	
		43	-	1390	2130	3030	4130	5450	6990	8780	10900	13200	-	
	55 Hz	32	1280	2100	3100	4300	5740	7410	9350	11600	14100	16800	19800	
		38	1020	1740	2640	3720	5020	6550	8330	10400	12700	15300	-	
		43	-	1510	2310	3280	4470	5870	7520	9410	11600	14000	-	
	65 Hz	32	1470	2400	3530	4900	6510	8380	10600	13000	15700	18700	21900	
		38	1170	2000	3010	4240	5690	7400	9380	11700	14200	17000	-	
		43	-	1730	2640	3740	5070	6640	8460	10600	12900	-	-	
	70 Hz	32	Information Available on Request											
		38												
		43												
	Compressor Voltage: **220-240V Δ / *380-420V Y - 3 - 50Hz													
	Fan Motor Voltage: 230V - 1 - 50Hz													

DANFOSS BOCK® Plusbox VSD UNITS

Unit Model: SHGX34e/215-4S R134A

Unit Model	Comp Speed	Amb Temp °C	Refrigeration Capacity Watts										
			Based on 10K suction gas superheat & 3.0K sub-cooling (outside cond.)										
			Evaporating Temperature °C										
			-40	-35	-30	-25	-20	-15	-10	-5	0	+5	+10
SHGX34e/215-4S (Three Phase)	25 Hz	32	-	-	812	1190	1670	2280	3000	3840	4810	5890	7090
		38	-	-	697	1030	1470	2030	2700	3490	4400	5430	6570
		43	-	-	608	903	1310	1830	2460	3210	4070	5050	6150
Danfoss Unit Code: 114V16134	35 Hz	32	-	-	1160	1680	2360	3210	4210	5380	6700	8180	9810
		38	-	-	991	1460	2080	2860	3790	4890	6130	7540	9090
		43	-	-	864	1280	1850	2570	3450	4480	5670	7010	8500
Nominal HP: 5.0 hp	45 Hz	32	-	-	1470	2130	2990	4040	5290	6740	8370	10200	12200
		38	-	-	1260	1850	2630	3600	4760	6120	7660	9370	11300
		43	-	-	1100	1630	2340	3240	4340	5610	7070	8710	10600
Bock Compressor: HGX34e/215-4 S	50 Hz (1450 rpm)	32	-	-	1620	2340	3270	4430	5790	7360	9130	11100	13300
		38	-	-	1390	2030	2880	3940	5210	6680	8350	10200	12300
		43	-	-	1210	1790	2570	3550	4740	6130	7710	9480	11500
Comp Displacement: (50Hz / 1450rpm) 18.8 m³/h	55 Hz	32	-	-	1760	2540	3550	4790	6260	7950	9840	12000	14300
		38	-	-	1510	2200	3120	4270	5630	7210	8990	11000	13200
		43	-	-	1320	1940	2780	3840	5120	6610	8310	10200	12300
Comp Max Working Current 50Hz: *Y = 10.5 amps **Δ = 18.3 amps	65 Hz	32	-	-	2020	2910	4060	5470	7120	9020	11200	13500	16000
		38	-	-	1730	2520	3570	4860	6400	8180	10200	12400	14800
		43	-	-	1510	2220	3180	4380	5830	7500	9390	11500	13800
Condenser Fan (Max) Current = 2.6 amps Consumption = 600w	70 Hz	32	Information Available on Request										
		38											
		43											
Condenser Airflow: 7895 m³/h at 50Hz													
Shut Off Valves: Liquid Line: 1/2" Suction Line: 1-1/8"													
Receiver Capacity: 8.0 litres													
Unit Weight: 201 kg													
Compressor Voltage: **220-240V Δ / *380-420V Y - 3 - 50Hz													
Fan Motor Voltage: 230V - 1 - 50Hz													

DANFOSS BOCK® Plusbox VSD UNITS

Unit Model: SHGX34e/215-4S R513A

Unit Model	Comp Speed	Amb Temp °C	Refrigeration Capacity Watts										
			Based on 10K suction gas superheat & 3.0K sub-cooling (outside cond.)										
			Evaporating Temperature °C										
			-40	-35	-30	-25	-20	-15	-10	-5	0	+5	+10
SHGX34e/215-4S (Three Phase) Danfoss Unit Code: 114V16134 Nominal HP: 5.0 hp Bock Compressor: HGX34e/215-4 S Comp Displacement: (50Hz / 1450rpm) 18.8 m³/h Comp Max Working Current 50Hz: *Y = 10.5 amps **Δ = 18.3 amps Condenser Fan (Max) Current = 2.6 amps Consumption = 600w Condenser Airflow: 7895 m³/h at 50Hz Shut Off Valves: Liquid Line: 1/2" Suction Line: 1-1/8" Receiver Capacity: 8.0 litres Unit Weight: 201 kg	25 Hz	32	-	-	897	1310	1820	2440	3170	4010	4960	6030	7210
		38	-	-	756	1120	1580	2150	2820	3600	4490	5490	6610
		43	-	-	645	963	1380	1900	2530	3260	4090	5040	6100
	35 Hz	32	-	-	1280	1850	2560	3420	4430	5580	6880	8330	9930
		38	-	-	1080	1580	2220	3010	3940	5010	6220	7580	9080
		43	-	-	914	1360	1950	2670	3530	4530	5670	6950	8360
	45 Hz	32	-	-	1620	2330	3230	4300	5550	6970	8560	10400	12300
		38	-	-	1360	1990	2800	3780	4920	6240	7730	9380	11200
		43	-	-	1160	1720	2450	3340	4410	5640	7030	8590	10300
	50 Hz (1450 rpm)	32	-	-	1780	2560	3540	4700	6060	7600	9320	11300	13300
		38	-	-	1500	2190	3060	4130	5370	6800	8410	10200	12200
		43	-	-	1280	1890	2680	3650	4810	6140	7640	9320	11200
	55 Hz	32	-	-	1930	2780	3830	5080	6540	8190	10100	12100	14300
		38	-	-	1620	2370	3320	4460	5800	7330	9040	11000	13000
		43	-	-	1390	2040	2900	3950	5190	6610	8220	10000	12000
	65 Hz	32	-	-	2210	3170	4370	5780	7420	9260	11400	13600	16000
		38	-	-	1860	2710	3780	5070	6570	8280	10200	12300	14600
		43	-	-	1590	2340	3300	4480	5870	7460	9250	11300	13400
	70 Hz	32	Information Available on Request										
		38											
		43											

Compressor Voltage: **220-240V Δ / *380-420V Y - 3 - 50Hz

Fan Motor Voltage: 230V - 1 - 50Hz

DANFOSS BOCK® Plusbox VSD UNITS

Unit Model: SHGX34e/255-4S R404A (R507)

Unit Model	Comp Speed	Amb Temp °C	Refrigeration Capacity Watts										
			Based on 10K suction gas superheat & 3.0K sub-cooling (outside cond.)										
			Evaporating Temperature °C										
			-40	-35	-30	-25	-20	-15	-10	-5	0	+5	+10
SHGX34e/255-4S (Three Phase) Danfoss Unit Code: 114V16135 Nominal HP: 6.0 hp Bock Compressor: HGX34e/255-4 S Comp Displacement: (50Hz / 1450rpm) 22.1 m ³ /h Comp Max Working Current 50Hz: *Y = 12.2 amps **Δ = 21.1 amps Condenser Fan (Max) Current = 2.6 amps Consumption = 600w Condenser Airflow: 7895 m ³ /h at 50Hz Shut Off Valves: Liquid Line: 1/2" Suction Line: 1-1/8" Receiver Capacity: 8.0 litres Unit Weight: 200 kg	25 Hz	32	1050	1520	2120	2860	3750	4790	6000	7380	8940	10700	-
		38	866	1280	1810	2470	3260	4210	5320	6580	8020	9630	-
		43	731	1090	1560	2150	2880	3740	4760	5930	7270	8780	-
	35 Hz	32	1490	2140	2970	3990	5200	6620	8250	10100	12200	14400	-
		38	1230	1800	2530	3440	4530	5810	7290	8970	10900	13000	-
		43	1040	1540	2190	3000	3990	5160	6510	8070	9830	11900	-
	45 Hz	32	1880	2700	3730	4990	6480	8200	10200	12400	14800	17500	-
		38	1560	2270	3180	4300	5630	7190	8970	11000	13300	15800	-
		43	1320	1940	2750	3750	4960	6370	8000	9860	12000	14300	-
	50 Hz (1450 rpm)	32	2070	2950	4080	5440	7060	8910	11100	13400	16000	18800	-
		38	1710	2480	3470	4690	6130	7810	9720	11900	14300	16900	-
		43	1440	2120	3000	4090	5390	6910	8660	10700	12900	15400	-
	55 Hz	32	2240	3200	4410	5870	7590	9570	11800	14300	17100	20000	-
		38	1850	2690	3760	5060	6600	8380	10400	12700	15200	18000	-
		43	1570	2300	3240	4410	5800	7420	9270	11400	13700	16300	-
	65 Hz	32	2560	3650	5010	6650	8570	10800	13200	16000	18900	22100	-
		38	2120	3070	4270	5730	7440	9410	11700	14100	16900	19800	-
		43	1790	2620	3690	4990	6530	8310	10400	12700	15200	-	-
	70 Hz	32	Information Available on Request										
		38											
		43											

Compressor Voltage: **220-240V Δ / *380-420V Y - 3 - 50Hz

Fan Motor Voltage: 230V - 1 - 50Hz

DANFOSS BOCK® Plusbox VSD UNITS

Unit Model: SHGX34e/255-4S R448A

Unit Model	Comp Speed	Amb Temp °C	Refrigeration Capacity Watts										
			Based on 10K suction gas superheat & 3.0K sub-cooling (outside cond.)										
			Evaporating Temperature °C										
			-40	-35	-30	-25	-20	-15	-10	-5	0	+5	+10
SHGX34e/255-4S (Three Phase) Danfoss Unit Code: 114V16135 Nominal HP: 6.0 hp Bock Compressor: HGX34e/255-4 S Comp Displacement: (50Hz / 1450rpm) 22.1 m ³ /h Comp Max Working Current 50Hz: *Y = 12.2 amps **Δ = 21.1 amps Condenser Fan (Max) Current = 2.6 amps Consumption = 600w Condenser Airflow: 7895 m ³ /h at 50Hz Shut Off Valves: Liquid Line: 1/2" Suction Line: 1-1/8" Receiver Capacity: 8.0 litres Unit Weight: 200 kg	25 Hz	32	770	1270	1880	2600	3470	4480	5640	6960	8440	10100	11900
		38	631	1090	1650	2310	3100	4010	5070	6280	7640	9160	10900
		43	536	957	1470	2070	2790	3630	4600	5710	6970	8380	9950
	35 Hz	32	1090	1790	2640	3650	4840	6210	7770	9520	11500	13600	16200
		38	894	1540	2320	3240	4310	5550	6970	8560	10400	12300	14500
		43	-	1360	2070	2900	3880	5020	6310	7770	9400	11300	-
	45 Hz	32	1380	2270	3330	4590	6050	7720	9590	11700	14000	16500	19100
		38	1140	1950	2920	4060	5380	6890	8590	10500	12600	14900	-
		43	-	1720	2610	3650	4850	6220	7760	9490	11400	13500	-
	50 Hz (1450 rpm)	32	1520	2490	3650	5010	6600	8390	10400	12700	15100	17700	20500
		38	1250	2140	3200	4440	5870	7490	9310	11400	13600	15900	-
		43	-	1890	2860	3990	5280	6750	8410	10300	12300	14500	-
	55 Hz	32	1650	2690	3950	5420	7110	9030	11200	13500	16100	18800	21700
		38	1360	2320	3470	4800	6330	8050	9980	12100	14400	16900	-
		43	-	2050	3100	4310	5690	7260	9000	11000	13100	-	-
	65 Hz	32	1890	3080	4500	6160	8050	10200	12500	15100	17800	20700	-
		38	1560	2660	3960	5450	7160	9060	11200	13500	15900	18600	-
		43	-	2350	3540	4900	6440	8160	10100	12200	14400	-	-
	70 Hz	32	Information Available on Request										
		38											
		43											

Compressor Voltage: **220-240V Δ / *380-420V Y - 3 - 50Hz

Fan Motor Voltage: 230V - 1 - 50Hz

DANFOSS BOCK® Plusbox VSD UNITS

Unit Model: SHGX34e/255-4S R449A

Unit Model	Comp Speed	Amb Temp °C	Refrigeration Capacity Watts											
			Based on 10K suction gas superheat & 3.0K sub-cooling (outside cond.)											
			Evaporating Temperature °C											
			-40	-35	-30	-25	-20	-15	-10	-5	0	+5	+10	
SHGX34e/255-4S (Three Phase) Danfoss Unit Code: 114V16135 Nominal HP: 6.0 hp Bock Compressor: HGX34e/255-4 S Comp Displacement: (50Hz / 1450rpm) 22.1 m ³ /h Comp Max Working Current 50Hz: *Y = 12.2 amps **Δ = 21.1 amps Condenser Fan (Max) Current = 2.6 amps Consumption = 600w Condenser Airflow: 7895 m ³ /h at 50Hz Shut Off Valves: Liquid Line: 1/2" Suction Line: 1-1/8" Receiver Capacity: 8.0 litres Unit Weight: 200 kg	25 Hz	32	766	1260	1860	2590	3450	4450	5600	6920	8390	10100	11900	
		38	627	1080	1630	2290	3070	3990	5040	6240	7590	9100	10800	
		43	531	949	1460	2060	2770	3600	4560	5670	6920	8320	9880	
	35 Hz	32	1090	1780	2620	3630	4810	6170	7720	9460	11400	13600	15900	
		38	888	1530	2300	3210	4280	5520	6920	8510	10300	12300	14400	
		43	-	1350	2050	2880	3850	4980	6260	7720	9340	11200	-	
	45 Hz	32	1380	2250	3310	4560	6010	7670	9540	11700	13900	16400	19000	
		38	1130	1940	2900	4030	5350	6850	8530	10500	12500	14800	-	
		43	-	1710	2590	3620	4810	6170	7710	9420	11400	13400	-	
	50 Hz (1450 rpm)	32	1510	2470	3620	4980	6560	8340	10400	12600	15000	17600	20400	
		38	1240	2130	3180	4410	5830	7440	9250	11300	13500	15900	-	
		43	-	1870	2830	3950	5240	6700	8350	10200	12200	14400	-	
	55 Hz	32	1640	2680	3920	5380	7070	8970	11100	13500	16000	18700	21600	
		38	1350	2310	3440	4760	6280	8000	9910	12100	14300	16800	-	
		43	-	2030	3070	4270	5650	7200	8940	10900	13000	-	-	
	65 Hz	32	1880	3060	4470	6120	8000	10100	12500	15000	17700	20600	-	
		38	1540	2640	3930	5420	7110	9000	11100	13400	15800	18500	-	
		43	-	2330	3510	4860	6390	8100	9990	12100	14300	-	-	
	70 Hz	32	Information Available on Request											
		38												
		43												
	Compressor Voltage: **220-240V Δ / *380-420V Y - 3 - 50Hz													
	Fan Motor Voltage: 230V - 1 - 50Hz													

DANFOSS BOCK® Plusbox VSD UNITS

Unit Model: SHGX34e/255-4S R134A

Unit Model	Comp Speed	Amb Temp °C	Refrigeration Capacity Watts											
			Based on 10K suction gas superheat & 3.0K sub-cooling (outside cond.)											
			Evaporating Temperature °C											
			-40	-35	-30	-25	-20	-15	-10	-5	0	+5	+10	
SHGX34e/255-4S (Three Phase) Danfoss Unit Code: 114V16135 Nominal HP: 6.0 hp Bock Compressor: HGX34e/255-4 S Comp Displacement: (50Hz / 1450rpm) 22.1 m ³ /h Comp Max Working Current 50Hz: *Y = 12.2 amps **Δ = 21.1 amps Condenser Fan (Max) Current = 2.6 amps Consumption = 600w Condenser Airflow: 7895 m ³ /h at 50Hz Shut Off Valves: Liquid Line: 1/2" Suction Line: 1-1/8" Receiver Capacity: 8.0 litres Unit Weight: 200 kg	25 Hz	32	-	-	980	1390	1960	2670	3540	4540	5680	6950	8340	
		38	-	-	847	1230	1750	2410	3220	4160	5230	6430	7750	
		43	-	-	750	1100	1590	2210	2970	3860	4880	6020	7270	
	35 Hz	32	-	-	1390	1970	2760	3760	4950	6330	7890	9610	11500	
		38	-	-	1210	1740	2470	3390	4510	5800	7270	8890	10700	
		43	-	-	1070	1560	2240	3110	4160	5380	6770	8310	9990	
	45 Hz	32	-	-	1770	2500	3490	4730	6220	7920	9820	12000	14200	
		38	-	-	1530	2200	3120	4270	5660	7250	9040	11100	13200	
		43	-	-	1360	1970	2830	3910	5220	6720	8420	10300	12400	
	50 Hz (1450 rpm)	32	-	-	1940	2740	3820	5180	6790	8640	10700	13000	15400	
		38	-	-	1680	2410	3420	4680	6190	7910	9850	12000	14300	
		43	-	-	1490	2170	3100	4280	5700	7330	9160	11200	13400	
	55 Hz	32	-	-	2110	2970	4140	5610	7340	9310	11600	13900	16500	
		38	-	-	1830	2620	3700	5060	6680	8530	10600	12900	15300	
		43	-	-	1620	2350	3360	4640	6160	7910	9860	12000	14300	
	65 Hz	32	-	-	2420	3400	4730	6390	8340	10600	13000	15700	18500	
		38	-	-	2100	3000	4230	5770	7590	9660	12000	14500	17100	
		43	-	-	1860	2690	3840	5280	7000	8950	11200	13500	16000	
	70 Hz	32	Information Available on Request											
		38												
		43												
	Compressor Voltage: **220-240V Δ / *380-420V Y - 3 - 50Hz													
	Fan Motor Voltage: 230V - 1 - 50Hz													

DANFOSS BOCK® Plusbox VSD UNITS

Unit Model: SHGX34e/255-4S R513A

Unit Model	Comp Speed	Amb Temp °C	Refrigeration Capacity Watts											
			Based on 10K suction gas superheat & 3.0K sub-cooling (outside cond.)											
			Evaporating Temperature °C											
			-40	-35	-30	-25	-20	-15	-10	-5	0	+5	+10	
SHGX34e/255-4S (Three Phase) Danfoss Unit Code: 114V16135 Nominal HP: 6.0 hp Bock Compressor: HGX34e/255-4 S Comp Displacement: (50Hz / 1450rpm) 22.1 m ³ /h Comp Max Working Current 50Hz: *Y = 12.2 amps **Δ = 21.1 amps Condenser Fan (Max) Current = 2.6 amps Consumption = 600w Condenser Airflow: 7895 m ³ /h at 50Hz Shut Off Valves: Liquid Line: 1/2" Suction Line: 1-1/8" Receiver Capacity: 8.0 litres Unit Weight: 200 kg	25 Hz	32	-	-	1070	1540	2140	2870	3740	4740	5860	7100	8460	
		38	-	-	914	1340	1890	2560	3370	4290	5340	6490	7760	
		43	-	-	798	1180	1690	2310	3060	3920	4900	5980	7180	
	35 Hz	32	-	-	1520	2170	3010	4030	5220	6580	8100	9760	11600	
		38	-	-	1300	1890	2650	3590	4690	5950	7360	8910	10600	
		43	-	-	1140	1670	2370	3230	4260	5430	6750	8200	9770	
	45 Hz	32	-	-	1920	2740	3780	5050	6520	8190	10100	12100	14200	
		38	-	-	1650	2380	3340	4500	5860	7400	9100	11000	13000	
		43	-	-	1440	2100	2980	4050	5310	6740	8340	10100	12000	
	50 Hz (1450 rpm)	32	-	-	2110	3000	4140	5520	7120	8910	10900	13100	15400	
		38	-	-	1810	2610	3650	4920	6390	8050	9880	11900	14000	
		43	-	-	1580	2310	3260	4420	5790	7330	9040	10900	12900	
	55 Hz	32	-	-	2290	3250	4480	5960	7670	9590	11700	14000	16400	
		38	-	-	1960	2830	3950	5310	6880	8660	10700	12800	15000	
		43	-	-	1710	2500	3520	4780	6240	7880	9700	11700	13800	
	65 Hz	32	-	-	2620	3710	5110	6770	8680	10900	13200	15700	18300	
		38	-	-	2240	3230	4500	6030	7790	9750	11900	14300	16700	
		43	-	-	1960	2850	4010	5420	7050	8880	10900	13100	15300	
	70 Hz	32	Information Available on Request											
		38												
		43												
	Compressor Voltage: **220-240V Δ / *380-420V Y - 3 - 50Hz													
	Fan Motor Voltage: 230V - 1 - 50Hz													

DANFOSS BOCK® Plusbox VSD UNITS

Unit Model: SHGX34e/315-4S R404A (R507)

Unit Model	Comp Speed	Amb Temp °C	Refrigeration Capacity Watts											
			Based on 10K suction gas superheat & 3.0K sub-cooling (outside cond.)											
			Evaporating Temperature °C											
			-40	-35	-30	-25	-20	-15	-10	-5	0	+5	+10	
SHGX34e/315-4S (Three Phase) Danfoss Unit Code: 114V16136 Nominal HP: 7.0 hp Bock Compressor: HGX34e/315-4 S Comp Displacement: (50Hz / 1450rpm) 27.3 m³/h Comp Max Working Current 50Hz: *Y = 14.7 amps **Δ = 25.5 amps Condenser Fan (Max) Current = 2.6 amps Consumption = 600w Condenser Airflow: 7020 m³/h at 50Hz Shut Off Valves: Liquid Line: 5/8" Suction Line: 1-3/8" Receiver Capacity: 10.0 litres Unit Weight: 207 kg	25 Hz	32	1400	2020	2770	3680	4750	6000	7440	9070	11000	13000	-	
		38	1160	1720	2400	3220	4190	5320	6630	8140	9830	11800	-	
		43	961	1480	2100	2840	3730	4770	5980	7370	8950	10800	-	
	35 Hz	32	1980	2840	3900	5150	6620	8320	10300	12500	14900	17600	-	
		38	1640	2420	3370	4500	5830	7370	9130	11200	13400	15900	-	
		43	1360	2080	2940	3970	5180	6590	8220	10100	12200	14600	-	
	45 Hz	32	2500	3590	4900	6460	8270	10400	12700	15300	18200	21400	-	
		38	2070	3050	4230	5630	7270	9140	11300	13700	16400	19300	-	
		43	1720	2620	3690	4960	6450	8170	10200	12400	14900	17700	-	
	50 Hz (1450 rpm)	32	2750	3940	5370	7050	9010	11300	13800	16600	19700	23100	-	
		38	2270	3340	4630	6150	7920	9940	12300	14800	17700	20800	-	
		43	1880	2860	4040	5420	7030	8870	11000	13400	16000	19000	-	
	55 Hz	32	2980	4260	5800	7620	9710	12100	14800	17800	21000	24600	-	
		38	2460	3620	5010	6640	8520	10700	13200	15900	18900	22200	-	
		43	2040	3100	4360	5840	7560	9530	11800	14300	17100	20200	-	
	65 Hz	32	3410	4870	6610	8640	11000	13700	16600	19800	23400	27200	-	
		38	2810	4130	5690	7520	9630	12100	14700	17700	20900	24500	-	
		43	2330	3530	4960	6620	8530	10800	13200	15900	19000	22300	-	
	70 Hz	32	Information Available on Request											
		38												
		43												
	Compressor Voltage: **220-240V Δ / *380-420V Y - 3 - 50Hz													
	Fan Motor Voltage: 230V - 1 - 50Hz													

DANFOSS BOCK® Plusbox VSD UNITS

Unit Model: SHGX34e/315-4S R448A

Unit Model	Comp Speed	Amb Temp °C	Refrigeration Capacity Watts										
			Based on 10K suction gas superheat & 3.0K sub-cooling (outside cond.)										
			Evaporating Temperature °C										
			-40	-35	-30	-25	-20	-15	-10	-5	0	+5	+10
SHGX34e/315-4S (Three Phase) Danfoss Unit Code: 114V16136 Nominal HP: 7.0 hp Bock Compressor: HGX34e/315-4 S Comp Displacement: (50Hz / 1450rpm) 27.3 m³/h Comp Max Working Current 50Hz: *Y = 14.7 amps **Δ = 25.5 amps Condenser Fan (Max) Current = 2.6 amps Consumption = 600w Condenser Airflow: 7020 m³/h at 50Hz Shut Off Valves: Liquid Line: 5/8" Suction Line: 1-3/8" Receiver Capacity: 10.0 litres Unit Weight: 207 kg	25 Hz	32	1040	1670	2410	3290	4330	5570	7030	8730	10700	13000	15500
		38	816	1420	2110	2930	3890	5030	6370	7950	9770	11900	14300
		43	652	1230	1880	2640	3530	4590	5840	7300	9010	11000	13300
	35 Hz	32	1470	2360	3400	4620	6060	7760	9730	12100	14700	17600	20900
		38	1160	2010	2980	4110	5430	6990	8810	11000	13400	16100	19200
		43	921	1740	2650	3710	4930	6380	8060	10100	12300	14900	-
	45 Hz	32	1850	2980	4280	5810	7590	9670	12100	14900	18000	21400	25300
		38	1460	2540	3760	5170	6810	8720	11000	13500	16400	19600	23200
		43	1170	2200	3350	4660	6180	7950	9990	12400	15100	18100	-
	50 Hz (1450 rpm)	32	2030	3270	4690	6360	8290	10600	13200	16100	19400	23100	27200
		38	1600	2790	4120	5650	7430	9500	11900	14600	17700	21100	-
		43	1280	2420	3670	5100	6750	8660	10900	13400	16300	19500	-
	55 Hz	32	2200	3540	5080	6870	8950	11400	14200	17300	20800	24600	28900
		38	1740	3020	4460	6110	8030	10300	12800	15700	18900	22500	-
		43	1390	2620	3980	5520	7290	9330	11700	14400	17400	20800	-
	65 Hz	32	2520	4050	5800	7820	10200	12900	15900	19300	23100	27300	-
		38	1990	3450	5090	6960	9100	11600	14400	17500	21000	24900	-
		43	-	3000	4540	6280	8270	10600	13200	16100	19400	-	-
	70 Hz	32	Information Available on Request										
		38											
		43											

Compressor Voltage: **220-240V Δ / *380-420V Y - 3 - 50Hz

Fan Motor Voltage: 230V - 1 - 50Hz

DANFOSS BOCK® Plusbox VSD UNITS

Unit Model: SHGX34e/315-4S R449A

Unit Model	Comp Speed	Amb Temp °C	Refrigeration Capacity Watts										
			Based on 10K suction gas superheat & 3.0K sub-cooling (outside cond.)										
			Evaporating Temperature °C										
			-40	-35	-30	-25	-20	-15	-10	-5	0	+5	+10
SHGX34e/315-4S (Three Phase) Danfoss Unit Code: 114V16136 Nominal HP: 7.0 hp Bock Compressor: HGX34e/315-4 S Comp Displacement: (50Hz / 1450rpm) 27.3 m³/h Comp Max Working Current 50Hz: *Y = 14.7 amps **Δ = 25.5 amps Condenser Fan (Max) Current = 2.6 amps Consumption = 600w Condenser Airflow: 7020 m³/h at 50Hz Shut Off Valves: Liquid Line: 5/8" Suction Line: 1-3/8" Receiver Capacity: 10.0 litres Unit Weight: 207 kg	25 Hz	32	1040	1660	2390	3270	4300	5540	6990	8680	10700	12900	15400
		38	811	1410	2100	2900	3860	4990	6330	7890	9710	11800	14200
		43	647	1220	1870	2620	3500	4550	5790	7250	8950	10900	13200
	35 Hz	32	1460	2350	3370	4590	6020	7710	9680	12000	14600	17500	20800
		38	1150	1990	2960	4080	5400	6950	8750	10900	13300	16000	19100
		43	913	1730	2630	3680	4900	6330	8010	9960	12200	14800	-
	45 Hz	32	1850	2960	4260	5770	7550	9620	12100	14800	17900	21300	25100
		38	1450	2520	3730	5130	6760	8660	10900	13400	16300	19500	23100
		43	1160	2180	3320	4620	6130	7890	9920	12300	15000	18000	-
	50 Hz (1450 rpm)	32	2020	3250	4670	6320	8240	10500	13100	16000	19300	23000	27000
		38	1590	2760	4090	5610	7380	9430	11800	14500	17600	21000	-
		43	1270	2400	3640	5060	6700	8600	10800	13300	16200	19400	-
	55 Hz	32	2190	3520	5050	6830	8900	11300	14100	17200	20700	24500	28700
		38	1730	3000	4430	6070	7970	10200	12700	15600	18800	22400	-
		43	1380	2600	3940	5470	7230	9260	11600	14300	17300	20600	-
	65 Hz	32	2510	4030	5770	7780	10100	12800	15800	19200	23000	27200	-
		38	1970	3430	5050	6910	9040	11500	14300	17400	20900	24800	-
		43	-	2970	4510	6230	8200	10500	13100	16000	19200	-	-
	70 Hz	32	Information Available on Request										
		38											
		43											

Compressor Voltage: **220-240V Δ / *380-420V Y - 3 - 50Hz

Fan Motor Voltage: 230V - 1 - 50Hz

DANFOSS BOCK® Plusbox VSD UNITS

Unit Model: SHGX34e/315-4S R134a

Unit Model	Comp Speed	Amb Temp °C	Refrigeration Capacity Watts											
			Based on 10K suction gas superheat & 3.0K sub-cooling (outside cond.)											
			Evaporating Temperature °C											
			-40	-35	-30	-25	-20	-15	-10	-5	0	+5	+10	
SHGX34e/315-4S (Three Phase) Danfoss Unit Code: 114V16136 Nominal HP: 7.0 hp Bock Compressor: HGX34e/315-4 S Comp Displacement: (50Hz / 1450rpm) 27.3 m³/h Comp Max Working Current 50Hz: *Y = 14.7 amps **Δ = 25.5 amps Condenser Fan (Max) Current = 2.6 amps Consumption = 600w Condenser Airflow: 7020 m³/h at 50Hz Shut Off Valves: Liquid Line: 5/8" Suction Line: 1-3/8" Receiver Capacity: 10.0 litres Unit Weight: 207 kg	25 Hz	32	-	-	1320	1830	2510	3360	4380	5580	6970	8540	10300	
		38	-	-	1140	1620	2250	3030	3980	5110	6410	7890	9550	
		43	-	-	1010	1450	2040	2770	3670	4730	5950	7360	8940	
	35 Hz	32	-	-	1870	2600	3550	4730	6150	7810	9710	11900	14300	
		38	-	-	1620	2300	3180	4270	5590	7140	8920	11000	13200	
		43	-	-	1430	2060	2880	3910	5150	6610	8290	10200	12400	
	45 Hz	32	-	-	2370	3290	4490	5970	7730	9780	12200	14800	17600	
		38	-	-	2060	2910	4020	5390	7030	8950	11200	13600	16300	
		43	-	-	1810	2610	3640	4930	6470	8280	10400	12700	15300	
	50 Hz (1450 rpm)	32	-	-	2610	3620	4930	6540	8460	10700	13300	16100	19100	
		38	-	-	2270	3200	4410	5910	7700	9770	12200	14800	17700	
		43	-	-	1990	2860	4000	5400	7080	9040	11300	13800	16600	
	55 Hz	32	-	-	2840	3930	5340	7080	9150	11600	14300	17300	20500	
		38	-	-	2460	3470	4780	6400	8320	10600	13100	15900	19000	
		43	-	-	2160	3110	4330	5850	7650	9750	12200	14900	17800	
	65 Hz	32	-	-	3260	4500	6110	8080	10500	13100	16100	19500	23100	
		38	-	-	2830	3980	5470	7300	9470	12000	14800	17900	21300	
		43	-	-	2480	3560	4950	6670	8710	11100	13800	16700	20000	
	70 Hz	32	Information Available on Request											
		38												
		43												
	Compressor Voltage: **220-240V Δ / *380-420V Y - 3 - 50Hz													
	Fan Motor Voltage: 230V - 1 - 50Hz													

DANFOSS BOCK® Plusbox VSD UNITS

Unit Model: SHGX34e/315-4S R513A

Unit Model	Comp Speed	Amb Temp °C	Refrigeration Capacity Watts										
			Based on 10K suction gas superheat & 3.0K sub-cooling (outside cond.)										
			Evaporating Temperature °C										
			-40	-35	-30	-25	-20	-15	-10	-5	0	+5	+10
SHGX34e/315-4S (Three Phase) Danfoss Unit Code: 114V16136 Nominal HP: 7.0 hp Bock Compressor: HGX34e/315-4 S Comp Displacement: (50Hz / 1450rpm) 27.3 m³/h Comp Max Working Current 50Hz: *Y = 14.7 amps **Δ = 25.5 amps Condenser Fan (Max) Current = 2.6 amps Consumption = 600w Condenser Airflow: 7020 m³/h at 50Hz Shut Off Valves: Liquid Line: 5/8" Suction Line: 1-3/8" Receiver Capacity: 10.0 litres Unit Weight: 207 kg	25 Hz	32	-	-	1470	2050	2770	3660	4700	5920	7300	8860	10600
		38	-	-	1280	1810	2480	3290	4260	5380	6670	8130	9760
		43	-	-	1130	1610	2230	2980	3890	4940	6150	7520	9050
	35 Hz	32	-	-	2080	2890	3900	5130	6560	8220	10100	12200	14500
		38	-	-	1810	2550	3480	4610	5930	7470	9210	11200	13400
		43	-	-	1590	2270	3130	4170	5410	6840	8470	10400	12400
	45 Hz	32	-	-	2640	3650	4920	6430	8200	10300	12500	15100	17800
		38	-	-	2300	3220	4380	5780	7410	9280	11400	13800	16300
		43	-	-	2020	2870	3940	5230	6750	8500	10500	12700	15100
	50 Hz (1450 rpm)	32	-	-	2900	4010	5380	7030	8950	11200	13600	16300	19200
		38	-	-	2520	3530	4790	6310	8080	10100	12400	14900	17700
		43	-	-	2210	3140	4310	5710	7360	9240	11400	13800	16300
	55 Hz	32	-	-	3140	4340	5830	7600	9650	12000	14600	17500	20600
		38	-	-	2730	3830	5190	6810	8710	10900	13300	16000	18900
		43	-	-	2400	3410	4660	6170	7930	9940	12200	14700	17400
	65 Hz	32	-	-	3600	4960	6640	8630	11000	13600	16400	19600	22900
		38	-	-	3130	4370	5910	7740	9850	12300	14900	17900	21000
		43	-	-	2750	3890	5300	7000	8960	11200	13700	16400	19400
	70 Hz	32	Information Available on Request										
		38											
		43											

Compressor Voltage: **220-240V Δ / *380-420V Y - 3 - 50Hz

Fan Motor Voltage: 230V - 1 - 50Hz

DANFOSS BOCK® Plusbox VSD UNITS

Unit Model: SHGX34e/380-4S R404A (R507)

Unit Model	Comp Speed	Amb Temp °C	Refrigeration Capacity Watts										
			Based on 10K suction gas superheat & 3.0K sub-cooling (outside cond.)										
			Evaporating Temperature °C										
			-40	-35	-30	-25	-20	-15	-10	-5	0	+5	+10
SHGX34e/380-4S (Three Phase) Danfoss Unit Code: 114V16137 Nominal HP: 9.0 hp Bock Compressor: HGX34e/380-4 S Comp Displacement: (50Hz / 1450rpm) 33.1 m ³ /h Comp Max Working Current 50Hz: *Y = 18.0 amps **Δ = 31.2 amps Condenser Fan (Max) Current = 2.6 amps Consumption = 600w Condenser Airflow: 7020 m ³ /h at 50Hz Shut Off Valves: Liquid Line: 5/8" Suction Line: 1-3/8" Receiver Capacity: 10.0 litres Unit Weight: 206 kg	25 Hz	32	1890	2630	3530	4600	5850	7300	8960	10900	13000	15300	-
		38	1590	2260	3080	4040	5180	6500	8010	9720	11700	13800	-
		43	1340	1960	2710	3600	4640	5850	7240	8820	10700	12700	-
	35 Hz	32	2670	3700	4940	6400	8100	10100	12300	14700	17500	20400	-
		38	2230	3170	4300	5620	7160	8930	11000	13200	15700	18500	-
		43	1880	2750	3780	5000	6410	8030	9870	12000	14300	16900	-
	45 Hz	32	3370	4650	6180	7980	10100	12400	15100	18000	21100	24600	-
		38	2810	3990	5380	7010	8880	11000	13400	16100	19000	22200	-
		43	2370	3450	4730	6220	7930	9880	12100	14600	17300	20300	-
	50 Hz (1450 rpm)	32	3690	5090	6750	8700	11000	13500	16300	19400	22700	26300	-
		38	3080	4360	5870	7630	9650	12000	14500	17300	20400	23800	-
		43	2590	3770	5160	6770	8610	10700	13100	15700	18600	21700	-
	55 Hz	32	3990	5500	7290	9370	11800	14500	17400	20600	24100	27900	-
		38	3330	4710	6340	8220	10400	12800	15500	18500	21700	25200	-
		43	2800	4080	5570	7290	9250	11500	14000	16700	19700	-	-
	65 Hz	32	4550	6260	8270	10600	13300	16200	19400	22900	26600	30600	-
		38	3800	5360	7180	9270	11700	14300	17200	20400	23900	27600	-
		43	3190	4630	6300	8220	10400	12900	15500	18500	21700	-	-
	70 Hz	32	Information Available on Request										
		38											
		43											

Compressor Voltage: **220-240V Δ / *380-420V Y - 3 - 50Hz
Fan Motor Voltage: 230V - 1 - 50Hz

DANFOSS BOCK® Plusbox VSD UNITS

Unit Model: SHGX34e/380-4S R448A

Unit Model	Comp Speed	Amb Temp °C	Refrigeration Capacity Watts										
			Based on 10K suction gas superheat & 3.0K sub-cooling (outside cond.)										
			Evaporating Temperature °C										
			-40	-35	-30	-25	-20	-15	-10	-5	0	+5	+10
SHGX34e/380-4S (Three Phase) Danfoss Unit Code: 114V16137 Nominal HP: 9.0 hp Bock Compressor: HGX34e/380-4 S Comp Displacement: (50Hz / 1450rpm) 33.1 m³/h Comp Max Working Current 50Hz: *Y = 18.0 amps **Δ = 31.2 amps Condenser Fan (Max) Current = 2.6 amps Consumption = 600w Condenser Airflow: 7020 m³/h at 50Hz Shut Off Valves: Liquid Line: 5/8" Suction Line: 1-3/8" Receiver Capacity: 10.0 litres Unit Weight: 206 kg	25 Hz	32	1420	2200	3100	4140	5370	6800	8470	10400	12600	15100	17900
		38	1140	1900	2740	3710	4850	6160	7700	9470	11600	13900	16500
		43	925	1660	2460	3370	4420	5650	7070	8730	10700	12800	15300
	35 Hz	32	2000	3100	4350	5800	7470	9410	11700	14200	17100	20300	23800
		38	1600	2670	3850	5190	6740	8520	10600	13000	15600	18600	21900
		43	1310	2330	3460	4720	6150	7810	9710	11900	14400	17200	-
	45 Hz	32	2520	3900	5470	7260	9320	11700	14400	17400	20800	24500	28500
		38	2020	3360	4840	6510	8400	10600	13100	15800	18900	22400	-
		43	1640	2940	4350	5910	7670	9680	12000	14600	17500	20700	-
	50 Hz (1450 rpm)	32	2750	4270	5980	7930	10200	12700	15600	18800	22400	26300	-
		38	2210	3680	5290	7110	9160	11500	14200	17100	20400	24000	-
		43	-	3220	4760	6460	8360	10600	13000	15700	18800	-	-
	55 Hz	32	2980	4260	6470	8560	11000	13700	16700	20100	23800	27900	-
		38	2390	3980	5720	7670	9870	12400	15200	18300	21700	25500	-
		43	-	3490	5140	6970	9010	11300	13900	16800	20000	-	-
	65 Hz	32	3400	5270	7360	9720	12400	15400	18700	22400	26300	30600	-
		38	2730	4540	6510	8700	11200	13900	17000	20300	24000	-	-
		43	-	3980	5860	7910	10200	12800	15600	18700	22100	-	-
	70 Hz	32	Information Available on Request										
		38											
		43											

Compressor Voltage: **220-240V Δ / *380-420V Y - 3 - 50Hz

Fan Motor Voltage: 230V - 1 - 50Hz

DANFOSS BOCK® Plusbox VSD UNITS

Unit Model: SHGX34e/380-4S R449A

Unit Model	Comp Speed	Amb Temp °C	Refrigeration Capacity Watts										
			Based on 10K suction gas superheat & 3.0K sub-cooling (outside cond.)										
			Evaporating Temperature °C										
			-40	-35	-30	-25	-20	-15	-10	-5	0	+5	+10
SHGX34e/380-4S (Three Phase) Danfoss Unit Code: 114V16137 Nominal HP: 9.0 hp Bock Compressor: HGX34e/380-4 S Comp Displacement: (50Hz / 1450rpm) 33.1 m³/h Comp Max Working Current 50Hz: *Y = 18.0 amps **Δ = 31.2 amps Condenser Fan (Max) Current = 2.6 amps Consumption = 600w Condenser Airflow: 7020 m³/h at 50Hz Shut Off Valves: Liquid Line: 5/8" Suction Line: 1-3/8" Receiver Capacity: 10.0 litres Unit Weight: 206 kg	25 Hz	32	1410	2190	3080	4120	5340	6760	8420	10400	12600	15000	17800
		38	1130	1880	2720	3690	4810	6120	7650	9410	11500	13800	16400
		43	917	1640	2440	3350	4390	5610	7020	8660	10600	12800	15200
	35 Hz	32	1990	3080	4320	5760	7430	9360	11600	14100	17000	20200	23700
		38	1590	2650	3820	5160	6690	8470	10500	12900	15500	18500	21700
		43	1300	2310	3430	4680	6110	7750	9640	11800	14300	17100	-
	45 Hz	32	2500	3880	5440	7220	9260	11700	14300	17300	20600	24300	28400
		38	2010	3330	4800	6460	8350	10500	13000	15700	18800	22200	-
		43	1630	2920	4310	5860	7620	9610	11900	14500	17300	20600	-
	50 Hz (1450 rpm)	32	2740	4250	5950	7880	10100	12700	15500	18700	22200	26100	30300
		38	2200	3650	5250	7060	9090	11500	14100	17000	20300	23900	-
		43	-	3190	4720	6400	8300	10500	12900	15600	18700	-	-
	55 Hz	32	2960	4600	6430	8510	10900	13600	16600	20000	23700	27700	-
		38	2380	3950	5680	7620	9800	12300	15100	18200	21600	25300	-
		43	-	3460	5100	6920	8940	11300	13800	16700	19900	-	-
	65 Hz	32	3380	5240	7310	9650	12300	15300	18600	22200	26200	30500	-
		38	2710	4500	6470	8640	11100	13800	16800	20200	23800	-	-
		43	-	3940	5810	7850	10200	12700	15500	18600	22000	-	-
	70 Hz	32	Information Available on Request										
		38											
		43											

Compressor Voltage: **220-240V Δ / *380-420V Y - 3 - 50Hz

Fan Motor Voltage: 230V - 1 - 50Hz

DANFOSS BOCK® Plusbox VSD UNITS

Unit Model: SHGX34e/380-4S R134a

Unit Model	Comp Speed	Amb Temp °C	Refrigeration Capacity Watts										
			Based on 10K suction gas superheat & 3.0K sub-cooling (outside cond.)										
			Evaporating Temperature °C										
			-40	-35	-30	-25	-20	-15	-10	-5	0	+5	+10
SHGX34e/380-4S (Three Phase) Danfoss Unit Code: 114V16137 Nominal HP: 9.0 hp Bock Compressor: HGX34e/380-4 S Comp Displacement: (50Hz / 1450rpm) 33.1 m ³ /h Comp Max Working Current 50Hz: *Y = 18.0 amps **Δ = 31.2 amps Condenser Fan (Max) Current = 2.6 amps Consumption = 600w Condenser Airflow: 7020 m ³ /h at 50Hz Shut Off Valves: Liquid Line: 5/8" Suction Line: 1-3/8" Receiver Capacity: 10.0 litres Unit Weight: 206 kg	25 Hz	32	-	-	1740	2380	3200	4210	5410	6820	8420	10300	12300
		38	-	-	1540	2130	2890	3830	4950	6260	7760	9460	11400
		43	-	-	1370	1930	2650	3530	4580	5820	7240	8840	10700
	35 Hz	32	-	-	2470	3360	4510	5910	7570	9490	11700	14100	16800
		38	-	-	2180	3010	4080	5380	6930	8720	10800	13100	15600
		43	-	-	1950	2730	3730	4950	6400	8090	10100	12200	14600
	45 Hz	32	-	-	3140	4260	5690	7440	9490	11900	14500	17400	20600
		38	-	-	2770	3810	5140	6760	8670	10900	13400	16100	19100
		43	-	-	2460	3450	4700	6220	8020	10100	12500	15100	17900
	50 Hz (1450 rpm)	32	-	-	3440	4670	6240	8140	10400	12900	15800	18900	22300
		38	-	-	3040	4180	5640	7400	9470	11900	14500	17500	20700
		43	-	-	2710	3780	5150	6800	8750	11000	13500	16300	19400
	55 Hz	32	-	-	3740	5070	6760	8800	11200	13900	17000	20300	23900
		38	-	-	3300	4540	6100	8000	10300	12800	15600	18700	22100
		43	-	-	2930	4100	5570	7350	9440	11900	14600	17500	20700
	65 Hz	32	-	-	4290	5800	7710	10100	12700	15700	19100	22700	26600
		38	-	-	3780	5190	6960	9100	11600	14400	17600	21000	24700
		43	-	-	3360	4690	6350	8360	10700	13400	16400	19600	23100
	70 Hz	32	Information Available on Request										
		38											
		43											

Compressor Voltage: **220-240V Δ / *380-420V Y - 3 - 50Hz

Fan Motor Voltage: 230V - 1 - 50Hz

DANFOSS BOCK® Plusbox VSD UNITS

Unit Model: SHGX34e/380-4S R513A

Unit Model	Comp Speed	Amb Temp °C	Refrigeration Capacity Watts										
			Based on 10K suction gas superheat & 3.0K sub-cooling (outside cond.)										
			Evaporating Temperature °C										
			-40	-35	-30	-25	-20	-15	-10	-5	0	+5	+10
SHGX34e/380-4S (Three Phase) Danfoss Unit Code: 114V16137 Nominal HP: 9.0 hp Bock Compressor: HGX34e/380-4 S Comp Displacement: (50Hz / 1450rpm) 33.1 m³/h Comp Max Working Current 50Hz: *Y = 18.0 amps **Δ = 31.2 amps Condenser Fan (Max) Current = 2.6 amps Consumption = 600w Condenser Airflow: 7020 m³/h at 50Hz Shut Off Valves: Liquid Line: 5/8" Suction Line: 1-3/8" Receiver Capacity: 10.0 litres Unit Weight: 206 kg	25 Hz	32	-	-	1930	2630	3500	4540	5760	7170	8750	10600	12500
		38	-	-	1710	2350	3150	4110	5240	6540	8020	9670	11500
		43	-	-	1520	2110	2850	3750	4800	6020	7400	8960	10700
	35 Hz	32	-	-	2720	3700	4910	6340	8000	9890	12100	14400	16900
		38	-	-	2410	3300	4410	5730	7260	9010	11000	13200	15600
		43	-	-	2140	2970	3990	5220	6650	8280	10200	12200	14400
	45 Hz	32	-	-	3450	4670	6160	7920	9950	12300	14800	17600	20600
		38	-	-	3040	4160	5530	7150	9020	11200	13500	16100	18900
		43	-	-	2700	3730	5000	6500	8250	10300	12500	14900	17500
	50 Hz (1450 rpm)	32	-	-	3780	5110	6730	8640	10900	13300	16000	19000	22200
		38	-	-	3330	4550	6040	7790	9810	12100	14600	17400	20300
		43	-	-	2960	4080	5460	7090	8960	11100	13500	16000	18800
	55 Hz	32	-	-	4100	5530	7270	9320	11700	14300	17200	20300	23600
		38	-	-	3610	4920	6520	8400	10600	13000	15700	18500	21600
		43	-	-	3210	4420	5890	7630	9630	11900	14400	17100	20000
	65 Hz	32	-	-	4680	6310	8260	10600	13200	16000	19200	22500	26100
		38	-	-	4120	5610	7400	9500	11900	14600	17500	20600	23900
		43	-	-	3660	5030	6680	8630	10900	13400	16100	19000	22100
	70 Hz	32	Information Available on Request										
		38											
		43											

Compressor Voltage: **220-240V Δ / *380-420V Y - 3 - 50Hz
Fan Motor Voltage: 230V - 1 - 50Hz

DANFOSS BOCK® Plusbox VSD UNITS

Unit Dimensions

Diagrams without access door

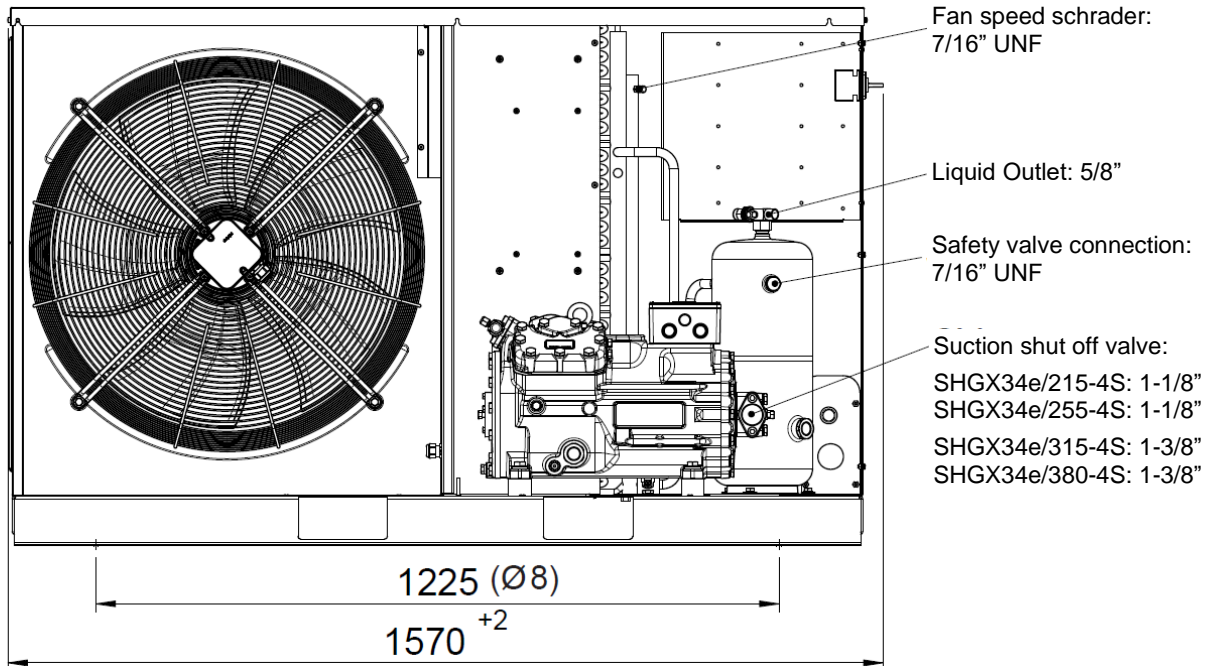

Liquid Receiver

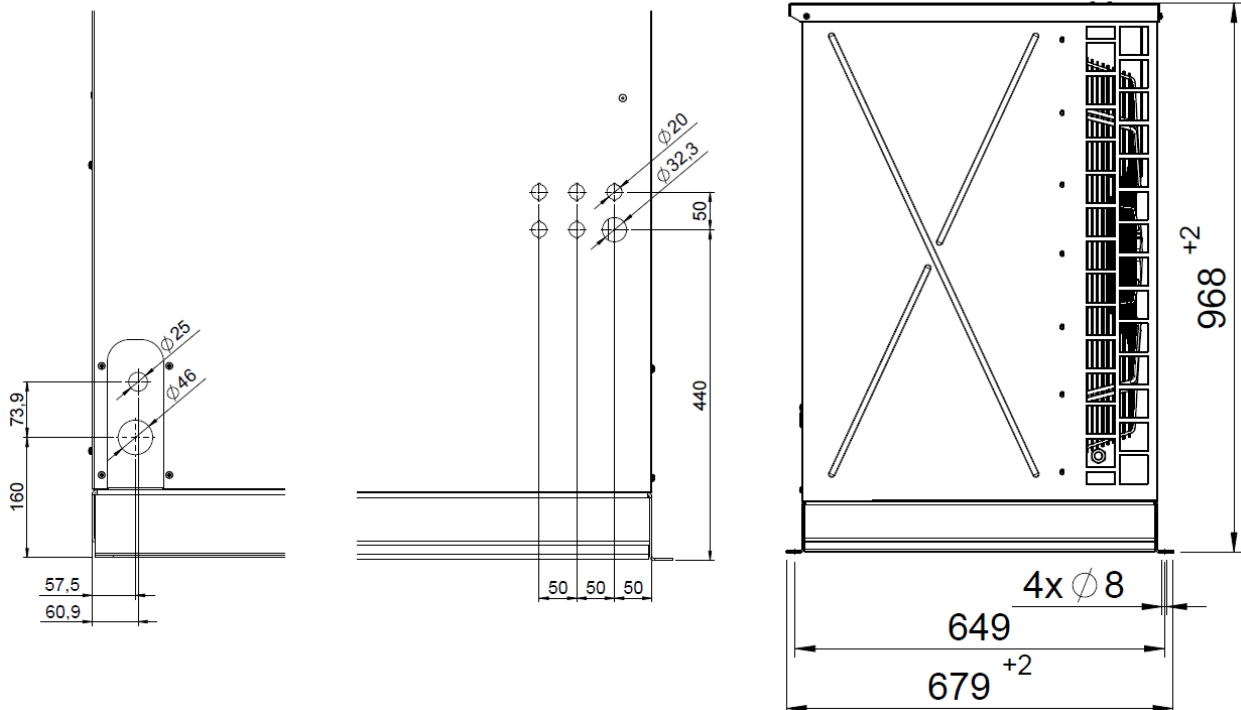
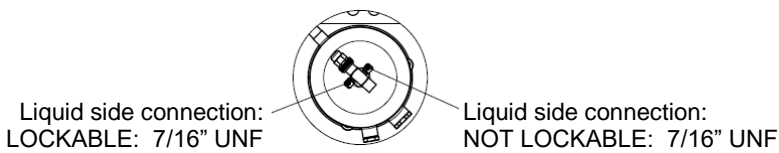

DANFOSS BOCK® Plusbox VSD UNITS

22.01.2025-Kanal

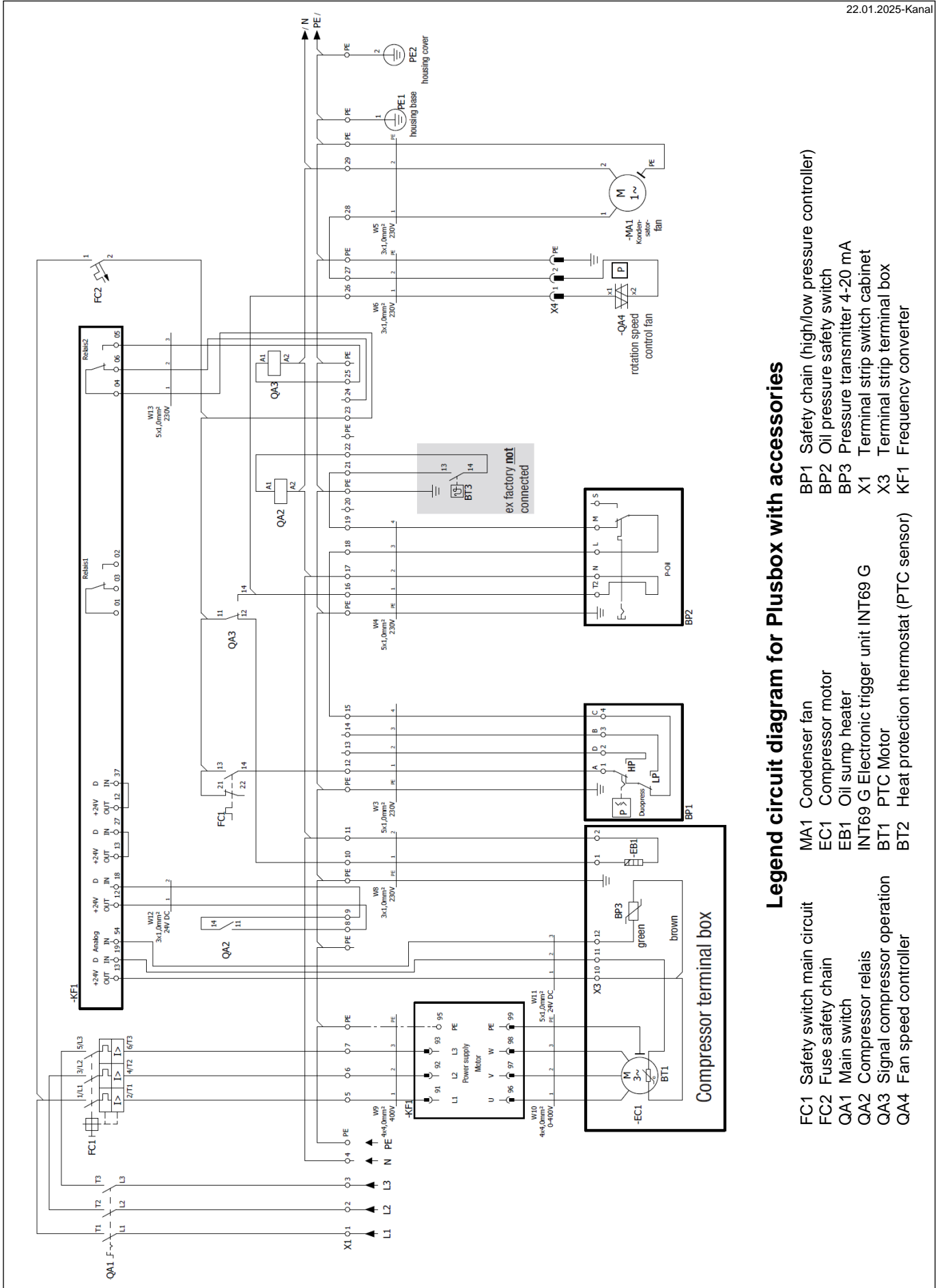

Legend circuit diagram for Plusbox with accessories

- | | | | | | |
|-----|-----------------------------|---------|---|-----|---|
| FC1 | Safety switch main circuit | MA1 | Condenser fan | BP1 | Safety chain (high/low pressure controller) |
| FC2 | Fuse safety chain | EC1 | Compressor motor | BP2 | Oil pressure safety switch |
| QA1 | Main switch | EB1 | Oil sump heater | BP3 | Pressure transmitter 4-20 mA |
| QA2 | Compressor relays | INT69 G | Electronic trigger unit INT69 G | X1 | Terminal strip switch cabinet |
| QA3 | Signal compressor operation | BT1 | PTC Motor | X3 | Terminal strip terminal box |
| QA4 | Fan speed controller | BT2 | Heat protection thermostat (PTC sensor) | KF1 | Frequency converter |

DANFOSS BOCK® Plusbox VSD UNITS

BOCK® Plusbox - Spare Parts

Item Description	Unit Model			
	SHGX34e/215-4S (114V6134)	SHGX34e/255-4S (114V6135)	SHGX34e/315-4S (114V6136)	SHGX34e/380-4S (114V6137)
BOCK Compressor	HGX34e/215-4 S Semi-hermetic comp Part No: 097B16062	HGX34e/255-4 Semi-hermetic comp Part No: 097B16063	HGX34e/315-4 S Semi-hermetic comp Part No: 097B16064	HGX34e/380-4 S Semi-hermetic comp Part No: 097B16065
Condenser Assembly	Air cooled condenser (82423) Part No: 097B2423	Air cooled condenser (82423) Part No: 097B2423	Air cooled condenser (82424) Part No: 097B2424	Air cooled condenser (82424) Part No: 097B2424
Fan/Motor Assembly	SET-VENTILAT.CPL. Ø630 230V AC Part No: 097B1207	SET-VENTILAT.CPL. Ø630 230V AC Part No: 097B1207	SET-VENTILAT.CPL. Ø630 230V AC Part No: 097B1207	SET-VENTILAT.CPL. Ø630 230V AC Part No: 097B1207
Frequency Converter Drive	Freq converter 7.5kw (FC-103P7K5) (81208) Part No: 134F7592	Freq converter 7.5kw (FC-103P7K5) (81208) Part No: 134F7592	Freq converter 11 kw (FC-103P11K) (81211) Part No: 134F7592	Freq converter 11 kw (FC-103P11K) (81211) Part No: 134F7592
Oil Separator	Oil Separator OS-16 Part No: 097B1116	Oil Separator OS-16 Part No: 097B1116	Oil Separator OS-22 Part No: 097B1119	Oil Separator OS-22 Part No: 097B1119
Receiver	Refrigerant Receiver 8 ltr Part No: 097B60028	Refrigerant Receiver 8 ltr Part No: 097B60028	Refrigerant Receiver 10 ltr Part No: 097B60029	Refrigerant Receiver 10 ltr Part No: 097B60029
Main/Emergency Switch 3 Pole	Part No: 097B51106	Part No: 097B51106	Part No: 097B51072	Part No: 097B51072
Speed Controller (condenser fan)	XGE-4C (1ph) Part No: 061H3140	XGE-4C (1ph) Part No: 061H3140	XGE-4C (1ph) Part No: 061H3140	XGE-4C (1ph) Part No: 061H3140
Sight Glass	SGP 12s N Ø12 solder Part No: 014L0193	SGP 12s N Ø12 solder Part No: 014L0193	SGP 16s N Ø16 solder Part No: 014L0199	SGP 16s N Ø16 solder Part No: 014L0199
Filter Drier	DML 16 cu.in Ø12 solder conn. Part No: 023Z484391	DML 16 cu.in Ø12 solder conn. Part No: 023Z484391	DML 16 cu.in Ø16 solder conn. Part No: 023Z483191	DML 16 cu.in Ø16 solder conn. Part No: 023Z483191
Dual Pressure Control	Part No: 060-539466/1VE	Part No: 060-539466/1VE	Part No: 060-539466/1VE	Part No: 060-539466/1VE
Oil Pressure Safety Switch	MP55 Differential pressure switch Part No: 060B017291	MP55 Differential pressure switch Part No: 060B017291	MP55 Differential pressure switch Part No: 060B017291	MP55 Differential pressure switch Part No: 060B017291

